

Gegendruck - Turbostromerzeugersatz Turbine / Hauptabmessungen

Typ: SG 49 / 3 / 6

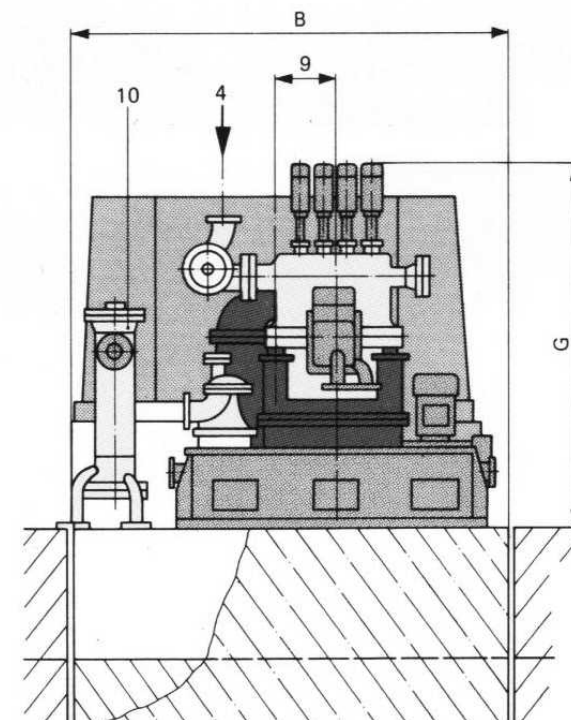
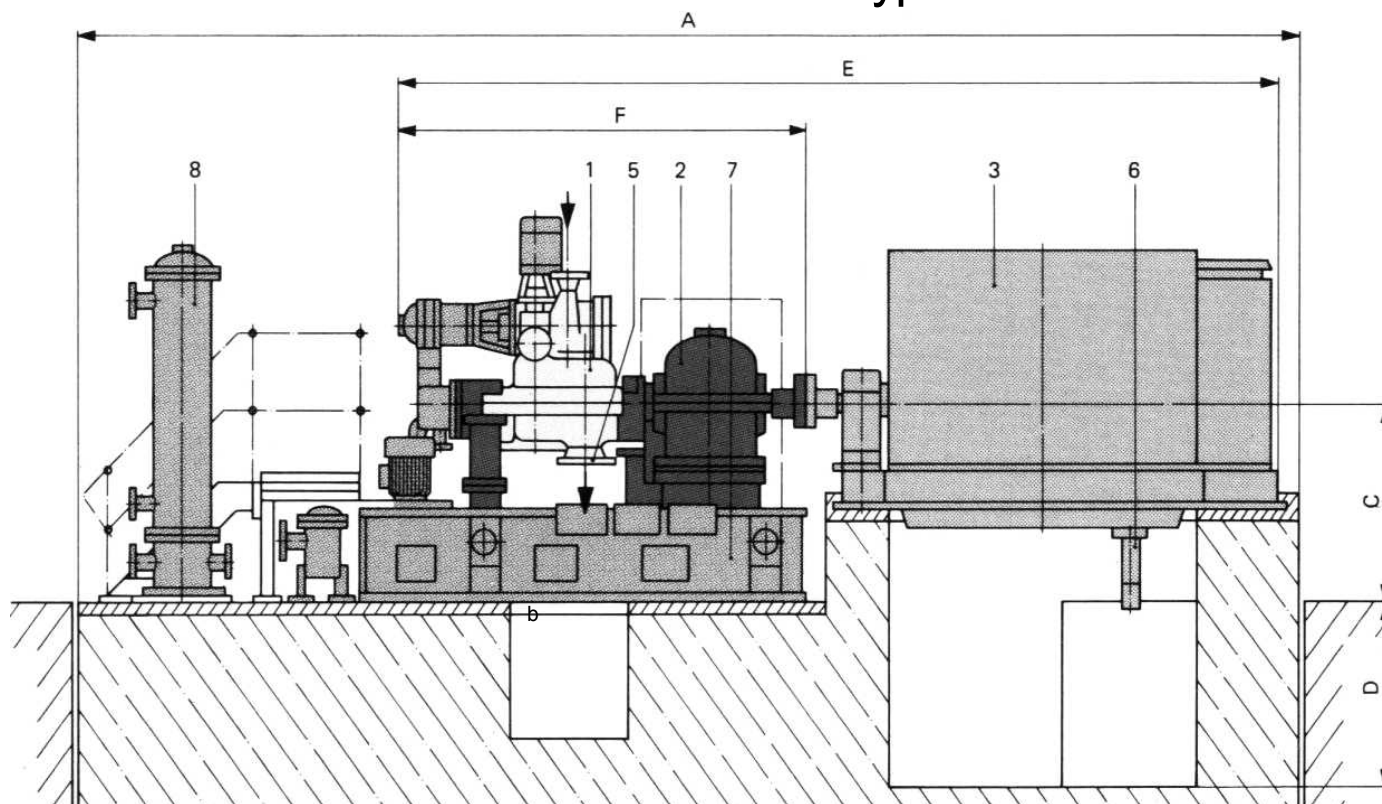

1	Turbine	A	5400	mm
2	Gear	B	3600	mm
4	Steam inlet	F	3400	mm
5	Steam outlet	G	2950	mm
7	Frame with oil tank	9	500	mm
8	Oil cooler		2600	mm
9	Gear axle distance		3750	mm
10	Gland steam condenser			

Alle Angaben ohne Gewähr!

Gegendruck - Turbostromerzeugersatz Turbine Back pressure turbo set

Abmessungen / General dimensions

[Typ: SG 49 / 3 / 6]

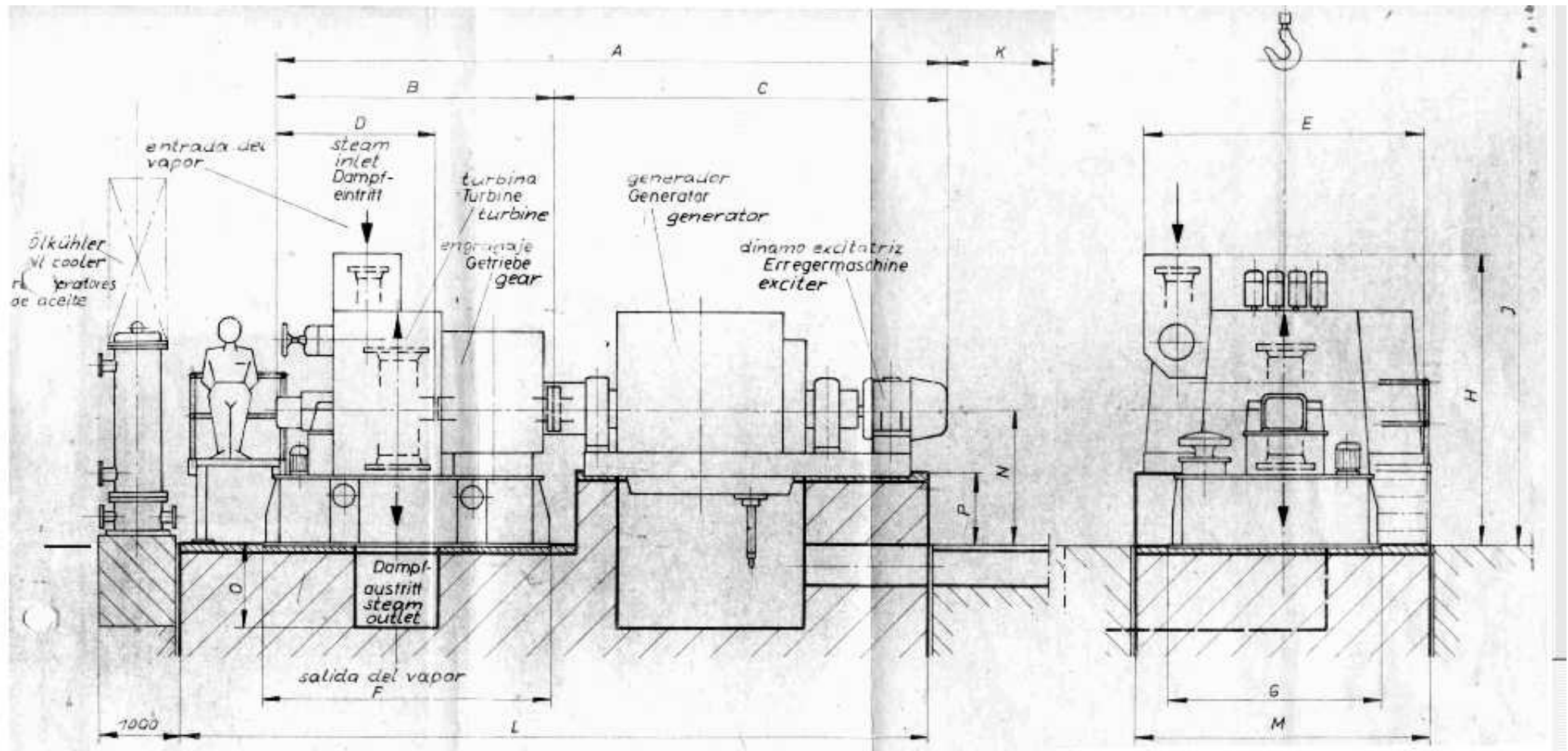

Gegendruck - Turbostromerzeugersatz Turbine Back pressure turbo set Abmessungen / General dimensions

[Typ: SG 49 / 3 / 6]

Alle Angaben sind unverbindlich!

Baumuster	A	B	C	D	E	F	G	H	J	K	L	M	N	O	P
SG 49/3/6	7200	3525	3675	2225	3300	3750	2600	3300	4500	1000	8800	3800	1570	1700	770

Hauptabmessungen / Maßangaben in mm
General dimension / dimensions in mm

Transportgewichte:

Turbinenblock	ca.19	to
Generator + Induktor	ca.11	to
Induktor	ca.4,5	to
Zubehör	ca.10	to